

PhaseGuard

In-line Interface Monitor for Turbidity or Colour



PhaseGuard Configuration

Language 0:Deutsch, 1:English
=1

Limits Mode 1:Off, 1:Exceeded, 2:
=0

Limits Upper limit
=1.000

Limits Lower limit
0.900

Integration
=1 s

Output 1 Invert 0:No, 1:Yes
=0

Output 2 Invert 0:No, 1:Yes
=0

Applications

- Monitoring and controlling of interfaces in beverages such as beer, fruit juices, etc.
- Optimization of beer / yeast separation steps
- Monitoring of clean in pipe processes (CIP), e.g. in the dairy industry
- Minimizing product losses and increasing yields
- Recognition of interfaces for product change over or product push-out
- Faster processing time due to better resolution of start-stop conditions

Advantages

- Sealless design
- Extremely low maintenance
- Recognition of interfaces by turbidity or colour
- Easy selection of the right model due to fix pathlengths
- Easy configuration and system integration

Industries

- Beverage
- Food and Dairy Industry
- Chemical Industry
- Pharmaceutical Industry

PhaseGuard

In-line Interface Monitor for Turbidity or Colour

Innovations with tangible benefits

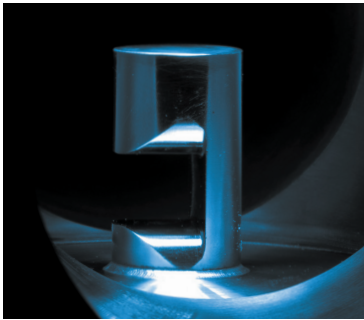

Sealless Design

The days of spending time doing routine maintenance for regular replacement of seals have gone. The sealless design with sapphire windows is well-proven and established. The PhaseGuard can be applied in virtually all interface monitoring/switching application in many different industries.



Simple Concept

Three models cover all possible applications: phase switching for turbidity (model T), for colour (model C) for high turbidity, like for example beer/yeast (model HT). Selecting the right model is easy thanks to fixed path-lengths and appropriate materials.



Quality- and Cost Optimized

The PhaseGuard is factory adjusted with an optimized universal measuring range based on absorption percentage. Once installed it is only necessary to perform an occasional zero check. The use of well-proven optical components guarantees the quality and reduces costs of purchase and maintenance. This results in a favourable total cost of ownership.

Flexible Configuration

For simple applications and system integration the instrument configuration and communication can be easily done using the integrated USB interface with a parameter file in combination with the existing outputs. For a more comfortable installation and operation the optional control unit SICON with touch screen technology and colour display can be connected.

PhaseGuard Configuration

Language 0:Deutsch, 1:English
=1

Limits Mode 1:Off, 1:Exceeded, 2:
=0

Limits Upper limit
=1.000

Limits Lower limit
=0.900

Integration
=1 s

Output 1 Invert 0:No, 1:Yes
=0

Output 2 Invert 0:No, 1:Yes
=0

Technical Data

Sensor:

Measuring principle:	Absorption
Wavelength:	LED 880 nm (turbidity) LED 430 nm (colour)
Measuring range:	0 .. 100 % Absorption
Resolution:	0.5 % Absorption
Path-length:	10 mm (models T & C) 5mm (model HT)
Outputs:	1 x 4 .. 20mA 2x Open-Collector-Transistor
Installation:	In-line housing Varivent® or compatible
Pipe diameter:	≥ DN 40 (models T&C) ≥ DN 65 (model HT)
Material sensor head:	Stainless steel, 316L
Material housing:	Stainless steel, 304
Windows:	Sapphire
Sample temperature:	-10 .. +100 °C
Cleaning:	CIP/SIP compatible up to 120 °C / 2 h
Pressure:	1 MPa (10 bar) / 100 °C
Ambient temperature:	-10 .. +50 °C
Ambient humidity:	0 .. 100 % RH
Protection degree:	IP 66
Power supply:	9 .. 30 VDC
Power consumption max:	2 W (3 W with Profibus DP)

Operation:

Configuration:	USB Interface and parameter file
Communication (optional):	Profibus DP, Modbus RTU

Control unit SICON (optional):

Power supply:	9 .. 30 VDC
Power consumption max.:	8 W
Display:	1/4 VGA, 3.5"
Operation:	Touch screen
Ambient temperature:	-10 .. +50 °C
Ambient humidity:	0 .. 100 % RH
Protection degree:	IP 66
Outputs:	4x 0/4 .. 20 mA, galvanic separated, 7x digital outputs, 5x digital inputs, freely configurable
Digital Interface:	Ethernet, SD-card
Optional:	Profibus DP, Modbus RTU, Connection of several sensors

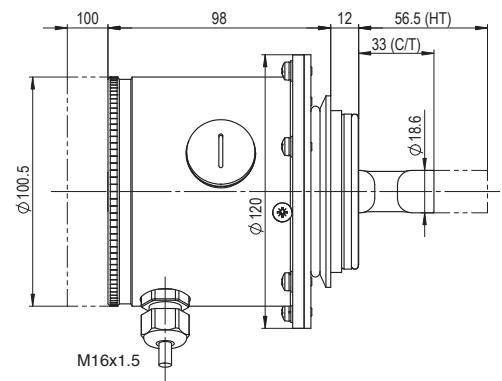

Your representative:

SIGRIST
PROCESS-PHOTOMETER

SIGRIST-PHOTOMETER AG
Hofurlistrasse 1 · CH-6373 Ennetbürgen
Tel. +41 41 624 54 54 Fax +41 41 624 54 55

www.photometer.com